

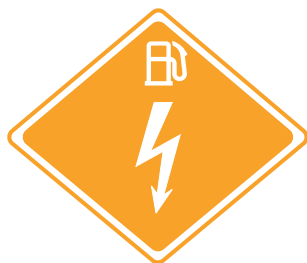

INFORMATION FOR FIRST AND SECOND RESPONDERS EMERGENCY RESPONSE GUIDE FOR VEHICLE



**HONDA
ZR-V e:HEV
HYBRID
2023 -**



Introduction

This document describes the items to be considered when carrying out rescue operations on the ZR-V e:HEV hybrid vehicle. Please read this manual carefully and observe the precautions for safe operation.

The ZR-V e:HEV is powered by both a motor and a petrol engine. The motor is driven by electricity supplied by the high-voltage battery and generator, while the high-voltage battery is charged not only by the generator but also by regenerative braking during driving.

© Honda Motor Europe Ltd.

Contents

0. Rescue sheet	4
1. Identification / recognition	5
2. Immobilization / stabilization / lifting	7
3. Disable direct hazards / Safety regulations	9
4. Access to the occupants	13
5. Stored energy / Liquids / Gases / Solids	18
6. In case of fire	21
7. In case of submersion	23
8. Towing / transportation / storage	24
9. Important additional information	27
10. Explanation of pictograms used	29

0. Rescue sheet



Honda ZR-V e:HEV
5dr SUV
(2023 -)

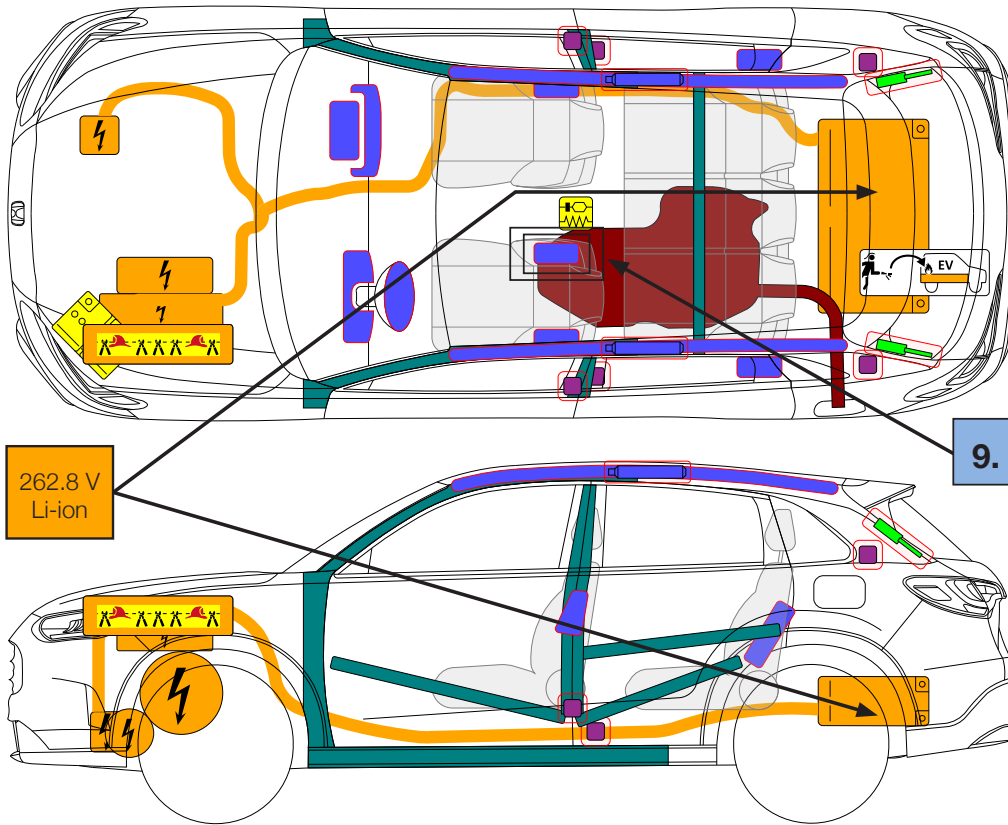

262.8 V
Li-ion

Airbag	Stored gas inflator	Seat belt pretensioner	Gas strut/preloaded spring	SRS controlunit
Battery low voltage	Battery pack, high-voltage	High voltage power cable	High voltage component	Cable cut
Special battery access	Fuel tank content gasoline/ethanol	High strength zone	Zone requiring special attention	

1. Identification / recognition

How to identify a ZR-V e:HEV

The appearance and features of the ZR-V e:HEV are described below. If the vehicle involved in the accident is the relevant model, please observe the precautions described in this manual for rescue work.

External view

ZR-V e:HEV: “ZR-V” and “e:HEV” emblem on the rear.



Type identification

The model and frame number can be found on the floor on the right side of the passenger seat, on a sticker on the B-pillar of the driver side, and behind the front windscreen on the driver side. The characters 4 thru 6 of the VIN will show the model number RZ4.



Stamping position floor



Sticker B-pillar driver side

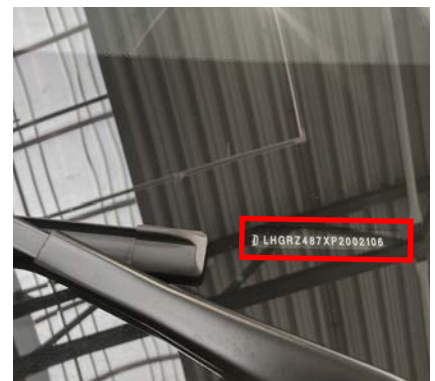

VIN behind front windscreen

About hybrid vehicles

The high-voltage system of the ZR-V e:HEV uses a total voltage of more than 260 V. Rescue operations therefore require attention to and response to high voltages.



- If the orange high-voltage cable or high-voltage cover is damaged and exposed wiring or terminals are found, never touch these exposed parts. Also, if you are unsure whether the exposed wires or terminals are high voltage parts or not, do not touch them. Unintentional touching may result in serious injury or death due to severe burns or electric shock.
- If you have no choice but to touch or may touch the exposed parts of the high-voltage cables or high-voltage components, always wear insulating protective equipment (insulated gloves, protective glasses and insulated shoes).

The following items should be prepared in advance for ZR-V e:HEV rescue activities.

- (1) Insulated protective equipment (insulated gloves, safety glasses, insulated shoes)
- (2) ABC fire extinguisher

Protective equipment for solvents [gas mask (for organic gases), rubber gloves (for chemical resistance)].

- High-voltage sites
- The high-voltage sections of the ZR-V e:HEV are shown below
- The area enclosed by the dotted line in the illustration shows the high-voltage area
- High-voltage cables can be identified by their orange colour

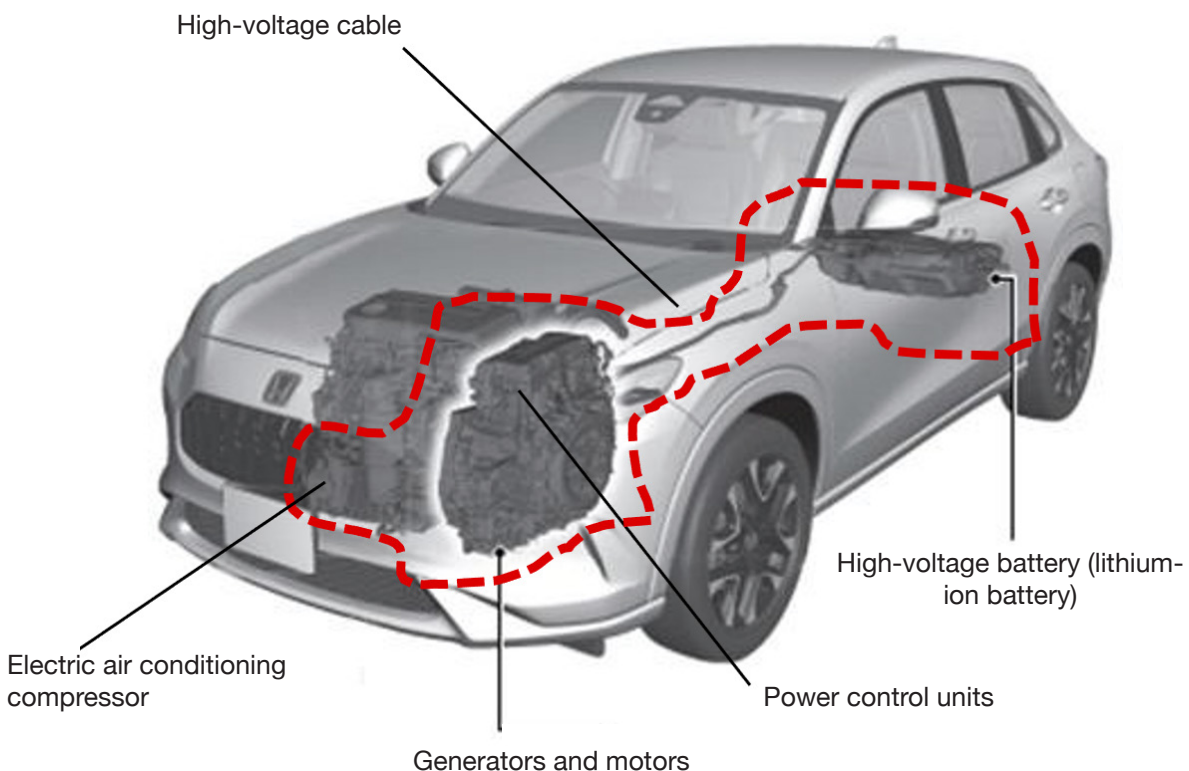

2. Immobilization / stabilization / lifting

Immobilize vehicle:

1. Block wheels, apply brake and push the P (park) button to select the P (park) position
2. Set parking brake by pulling the parking brake switch (P)



Lifting points:

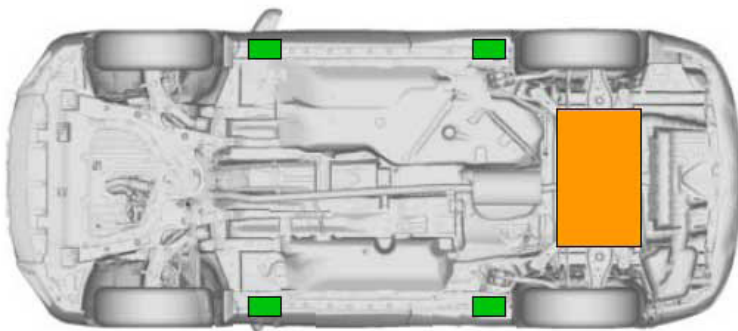

 Appropriate lifting points

 High voltage battery



Support and lift Airbag equipment should be installed away from high-voltage parts under the floor, exhaust and fuel systems, etc. This may cause damage to high-voltage parts or cause an unexpected fire due to heat.

When securing and stabilising the vehicle

Apply the parking brake as you would for a normal vehicle to stop the wheels. To further stabilize the vehicle, place a piece of wood or other support under the vehicle to deflate the tires or use a rescue lift airbag device. Use a rescue lift airbag device or similar to stabilize the vehicle.



- When lifting or jacking up the vehicle, do not allow objects to hit the high-voltage cables on the underside of the floor.
- Do not allow objects to hit the high voltage cables under the floor when lifting or jacking up the vehicle. If the high voltage cables are damaged or cut, the wiring will be exposed and unintentional touching may result in serious injury or death due to severe burns or electric shock from the high voltage.

Electric Parking Brake Forced Cancellation

Forced cancellation is performed when the system is abnormal and the parking brake cannot be released.

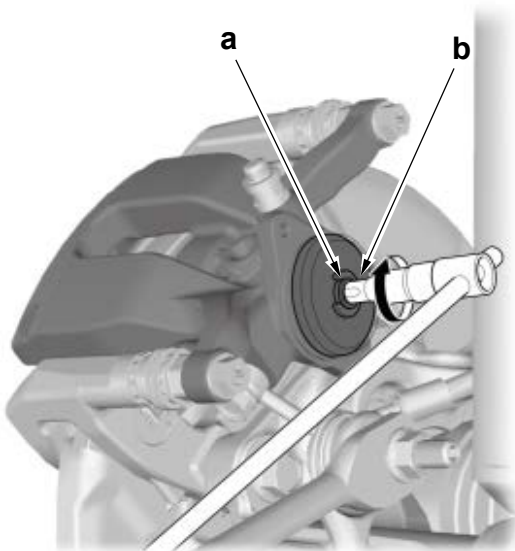

Procedure:

Turn the spindle (a) clockwise until parking brake is released.

Tool "b" details:

T type TORX socket (Commercially Available)

3. Disable direct hazards / Safety regulations

Vehicle Collision

In a collision severe enough to deploy one or more of the airbags, the Honda ZR-V e:HEV electrical system is designed to automatically open the high-voltage electrical contactors. This disconnects the high-voltage battery from the other high-voltage components and stops the flow of electricity in the high-voltage cables.

However, responders should always assume that the high-voltage system is powered on, and take the appropriate action described in this guide to power off the system.



- If the orange high-voltage cable or high-voltage cover has been damaged and exposed wiring or terminals, do not touch those exposed parts. Also, if you are unsure whether the exposed wires or terminals are high-voltage parts or not, do not touch them. Unintentional touching may result in serious injury or death due to severe burns or electric shock!
- Always wear insulating protective equipment [insulated gloves, safety glasses and insulated shoes] when unavoidably touching or potentially touching exposed parts of high-voltage cables or high-voltage components..
- Do not disconnect high-voltage sections. Exposure of high voltage parts by disconnection, even after high voltage disconnection, may result in serious injury or death due to severe burns or electric shock!
- Do not disconnect any airbags that have not deployed or seat belt pretensioners that have not deactivated. Airbags and seat belt pretensioners are equipped with high-pressure gas generators, which may cause serious injury or death if disconnected.
- Do not disconnect any airbags that have not deployed or seat belt pretensioners that have not deactivated. Airbags and seat belt pretensioners are equipped with high-pressure gas generators, which may cause serious injury or death if disconnected.
- Always allow at least 3 minutes to elapse before disconnecting the airbag system, as the system continues to function for 3 minutes after the power switch is switched OFF or the 12 V battery is disconnected. However, this is not a problem if all airbags have already deployed.
- Use hydraulic cutters or other equipment that does not produce flying sparks to avoid the risk of serious injury due to ignition caused by sparks.

Methods of shutting down high voltage systems

Depending on the damage to the vehicle, high voltage should be interrupted. High voltage can be interrupted by any of the methods described below. After the high voltage has been interrupted, normal rescue activities can be carried out.

Follow the flow chart below to select the easiest method.

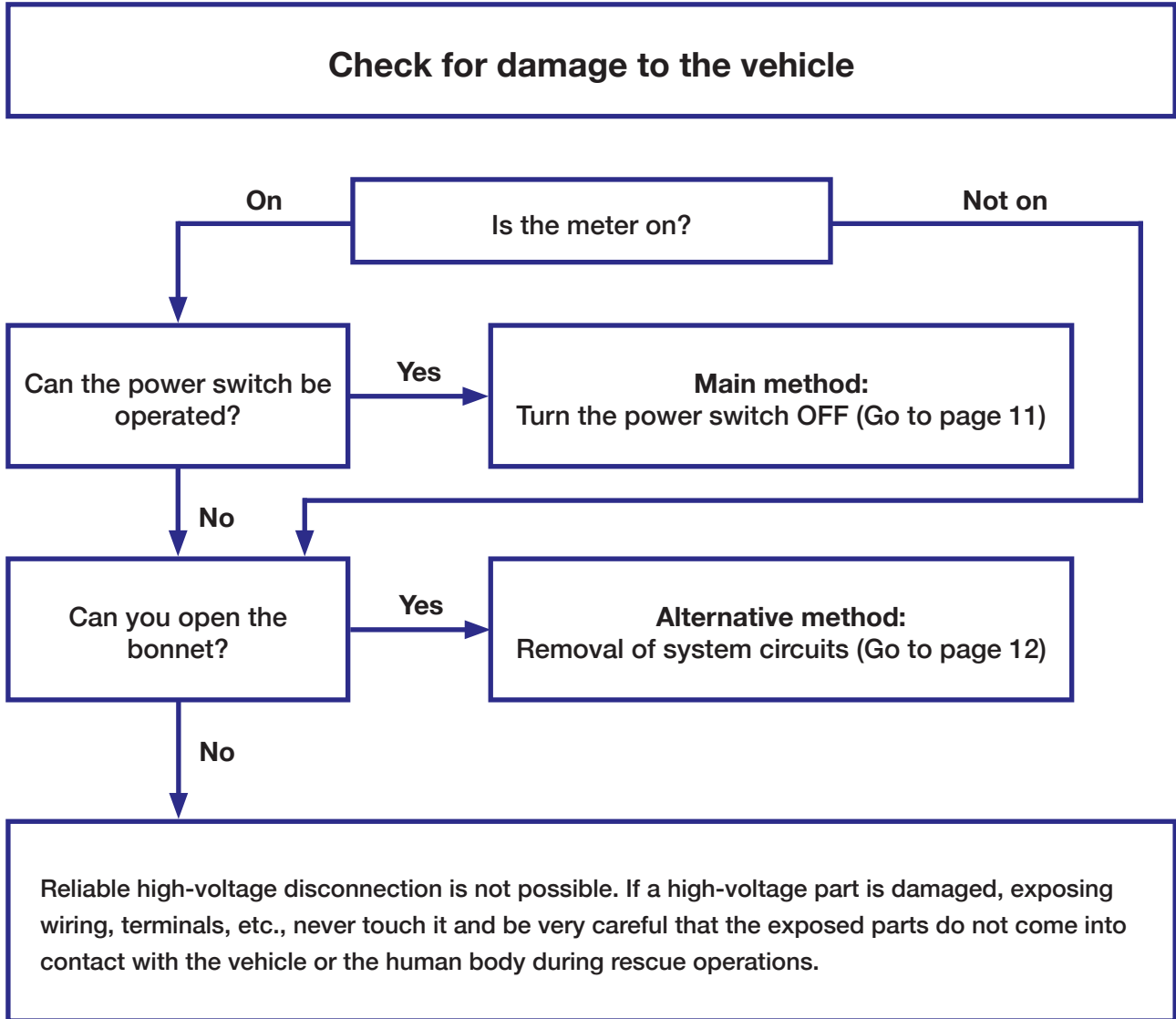

- If the orange high-voltage cable or high-voltage cover is damaged and exposed wiring or terminals are found, never touch these exposed parts. Also, if you are unsure whether the exposed wires or terminals are high voltage parts or not, do not touch them. Unintentional touching may result in serious injury or death due to severe burns or electric shock.
- If you have no choice but to touch or may touch the exposed parts of the high-voltage cables or high-voltage components, always wear insulating protective equipment [insulated gloves, protective glasses and insulated shoes].

Main method: Turn the power switch OFF.

If the vehicle is damaged but the power switch can still be operated:

Turn the power switch to OFF.

1. Press the parking switch.
2. Press and hold the power switch for approx. 2 seconds or more to turn it OFF.



Press and hold for more than 2 seconds.



Operating the power switch while the display in the meter is off may cause the system to start.

Check that all displays in the meter are off.

Ensure that all displays in the meter are off. To prevent unintended restarting, keep the keyless remote control at least 5 metres away from the vehicle



Even after the power switch has been switched off, it takes approximately 5 minutes for the electrical charge stored in the capacitor etc. to discharge. After the high voltage has been switched off, take care to avoid short circuits, etc.

Start rescue operations

Alternative method: Removal of system circuits.

Power If the switch cannot be operated but the bonnet can be opened, open the bonnet.

Open the bonnet.

Pull the bonnet release knob at the foot of the driver's seat towards you, pull up the lever at the centre of the front of the raised bonnet to release the locking mechanism and raise the bonnet.

If the above procedure cannot be carried out, use a crowbar or similar tool to pry open the bonnet. If possible, secure the opened bonnet with the stays provided!

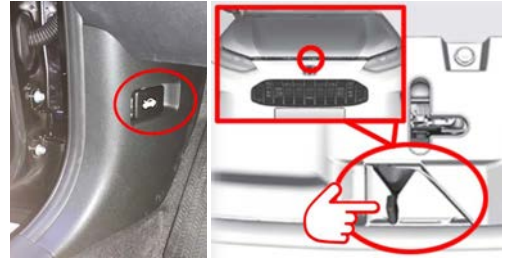

Disconnect the 12V battery.

Disconnect both the negative (-) and positive (+) terminals from the 12 V battery.

The high voltage system cannot be disconnected simply by disconnecting both the negative (-) and positive (+) terminals from the 12 V battery.

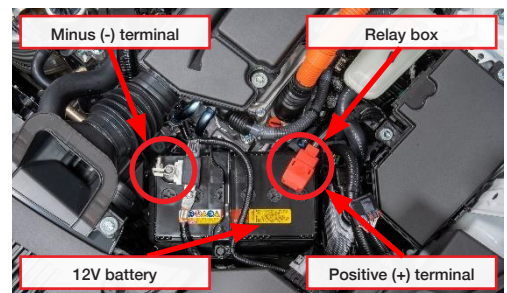

Disconnect the front terminal inside the relay box.

Remove the relay box cover and disconnect (or cut the wiring to) the "front terminals" shown on the right to interrupt the circuit of the high voltage system.

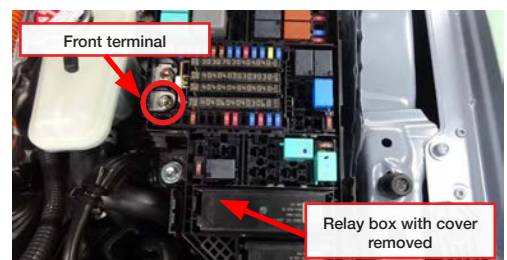

Even after the power switch has been switched off, it takes approximately 5 minutes for the electrical charge stored in the capacitor etc. to discharge. After the high voltage has been switched off, take care to avoid short circuits, etc.

Start rescue operations

4. Access to the occupants

Cut zone (cuttable area)

If it is necessary to cut the vehicle body or use hydraulic cutters, etc. to rescue the occupants, do so within the cut zones shown in the diagram below.

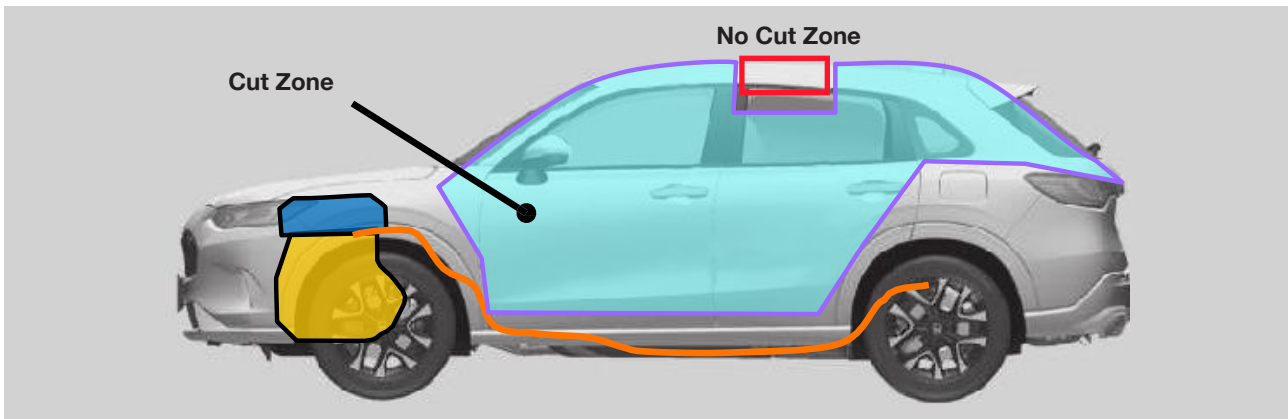

Do not cut the area near the high-pressure gas generator part of the side curtain airbag on the side of the vehicle (non-cut zone shown below). Do not disconnect the side curtain airbag near the high-pressure gas generator part on the side of the vehicle (non-cut zone shown below). Disconnection may result in serious injury or death. However, if the side curtain airbags are already deployed, disconnection is not a problem.

Multiple types of steel

The body of the Honda ZR-V e:HEV is made of multiple types of steel and are indicated by the colored areas.

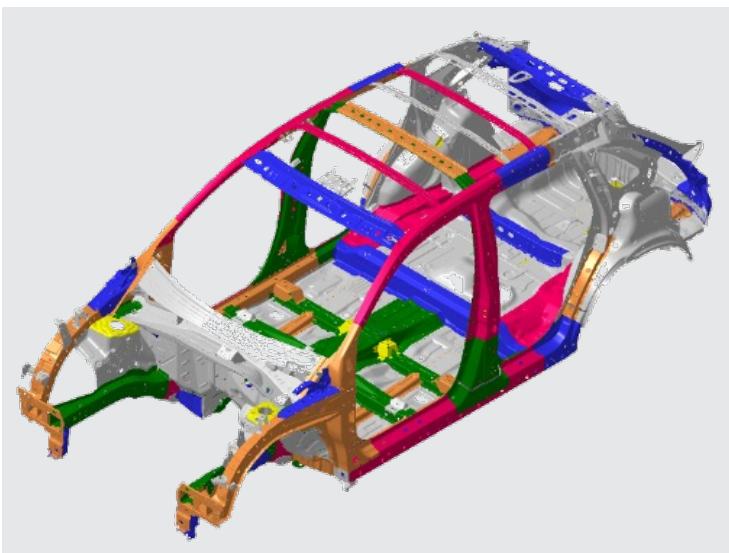

RED: 1500 Mpa (Hot-stamped)
ORANGE: 980 Mpa
GREEN: 780 Mpa
BLUE: 590 Mpa
GRAY: < 590 Mpa

Location of high-voltage components

If it is necessary to cut the vehicle body or use hydraulic cutters, etc., to rescue occupants, avoid areas near high-voltage cables and lithium-ion batteries on the underside of the vehicle body.



Do not disconnect high-voltage parts. In particular, lithium-ion batteries may cause serious injury or death due to severe burns or electric shock if high voltage parts are exposed by disconnection, even after the high voltage has been interrupted.

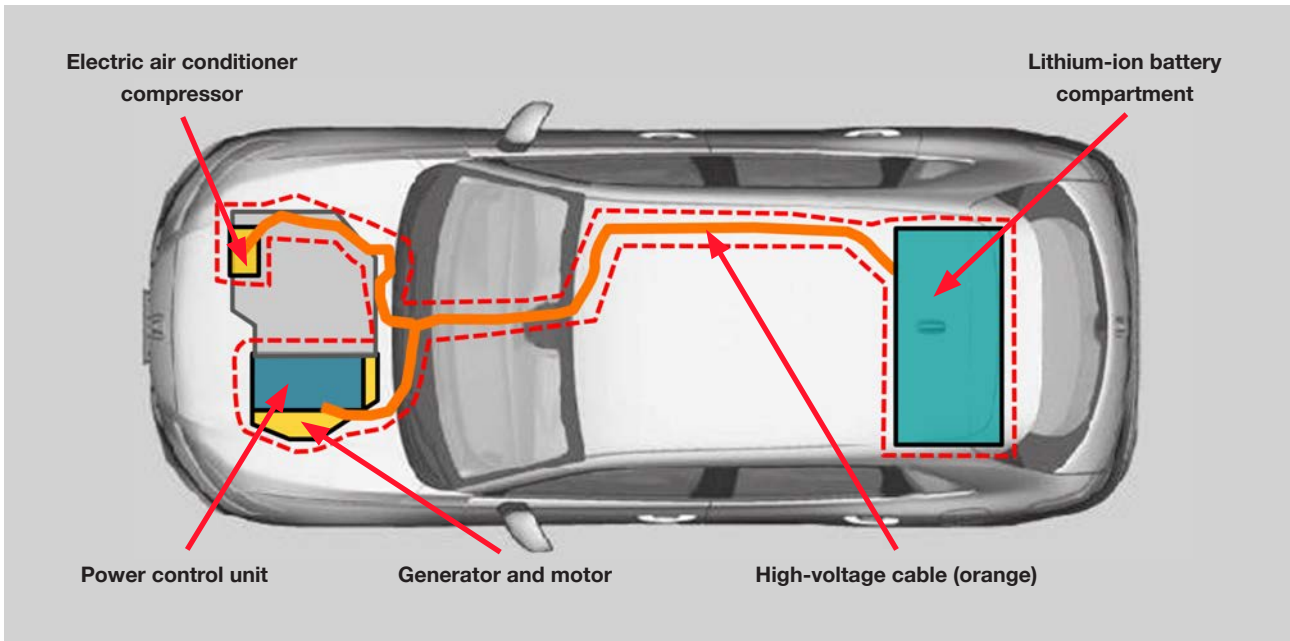

Glass types



- A. Laminated glass
- B. Tempered glass

Treatment overview

The ZR-V e:HEV is also powered by a petrol engine. As well as the same precautions as for normal gasoline engine vehicles, precautions and measures for high voltages must be taken as a precaution specific to hybrid vehicles.

Please read the following items carefully and take appropriate measures according to the situation during actual operation.

Pre-treatment of auxiliaries

Operate power windows, door locks, tailgate, etc. as required.

Important: If the 12 V battery connection is disconnected, the above electrical operations become impossible.

When rescuing occupants from inside the vehicle

- Adjust the position of the steering wheel if you need to make room for occupant rescue in the front seat.
- Push the lever down to adjust the handle position and pull the lever up to fix the handle position.

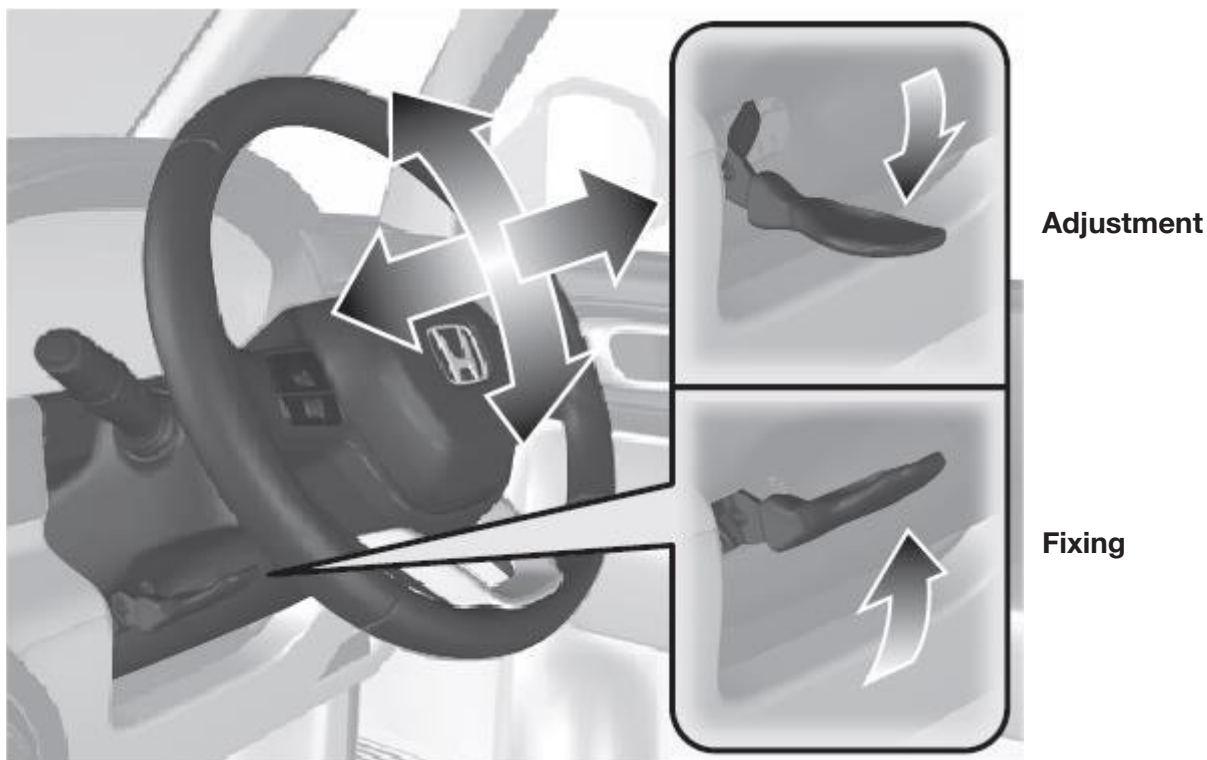

Front manual seat controls

Adjust the position of the front seat as required to secure space.

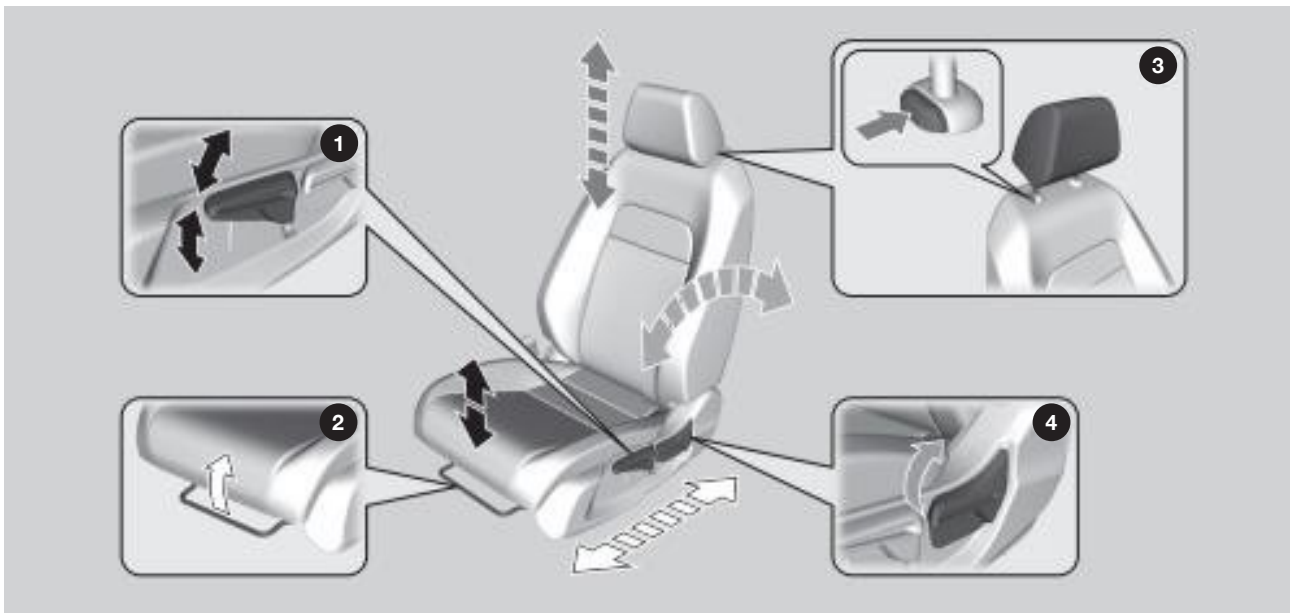

1 Height adjustment (driver's seat)

Repeatedly pull up / down on the lever to adjust the height.

2 Adjusting the front/rear position

Adjust the front/rear position while pulling up the lever.

3 Adjusting the headrest

To raise the headrest, pull it up. To lower, press and hold the knob while lowering.

4 Backrest angle adjustment

Adjust by pulling up on the lever.

Front power seat controls

Adjust the position of the front seats according to your space requirements



1 Height adjustment (driver's seat)

Adjust the height by moving the switch up or down.

2 Adjusting the front/rear position

Adjust the front-back position by moving the switch back and forth.

3 Adjusting the headrest

To raise the headrest, pull it up. To lower, press and hold the knob while lowering.

4 Backrest angle adjustment

Adjustment by moving the switch back and forth.

Opening the tailgate from inside

If you cannot open the tailgate, use the following procedure.

1. Use a flat-tip screwdriver and open the lid on the back of the tailgate.

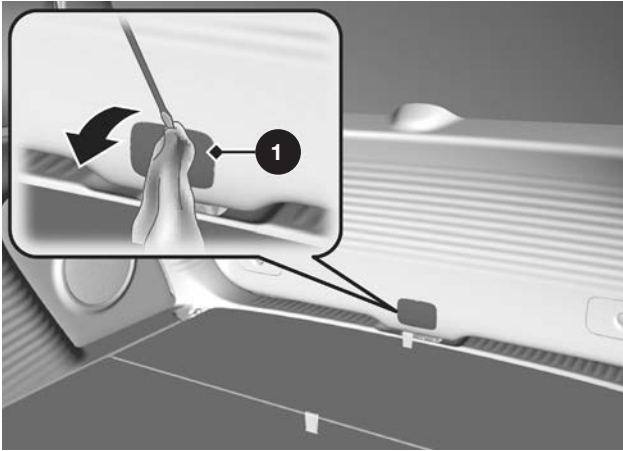

① Lid

2. To open the tailgate, push the tailgate while pushing the lever to the right with the flat-tip screwdriver.

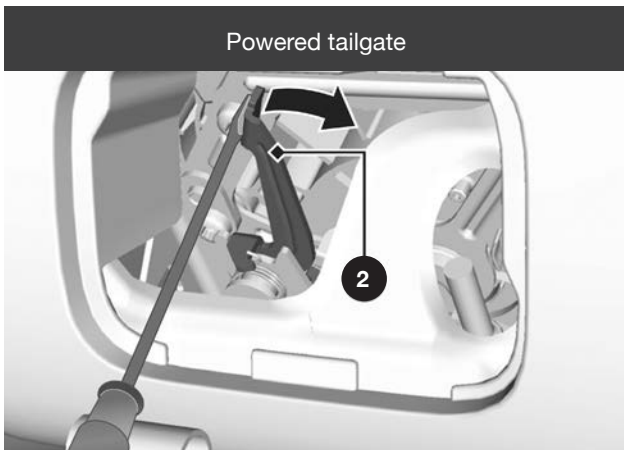

② Lever

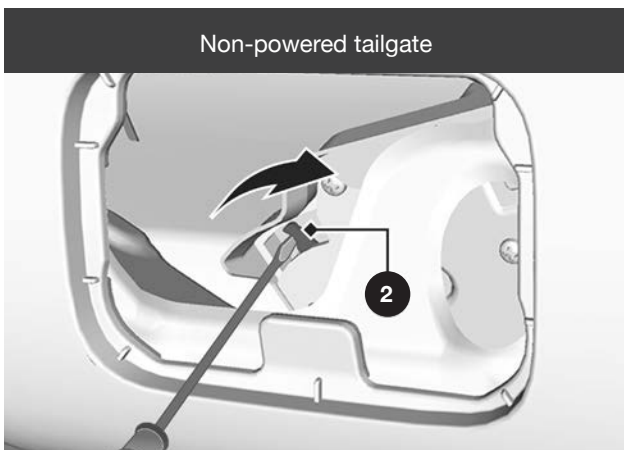

② Lever

5. Stored energy / Liquids / Gases / Solids

High voltage isolation

The ZR-V e:HEV is high voltage isolated.

- Both positive (+)/negative (-) poles of the high voltage circuit are isolated from the vehicle body.
- High-voltage equipment and high-voltage wiring are provided with cases and covers to eliminate exposure of the high-voltage parts.
- High-voltage electrical components and lithium-ion batteries are enclosed in cases and stored under the boot at the rear of the vehicle.
- The high-voltage wiring in the engine compartment is also isolated by cable covers.
- The high-voltage wiring is identified in orange.
- High-voltage areas are labelled with a caution label.

High-voltage disconnection

The ZR-V e:HEV is equipped with a system that can shut off high voltages.

- In the event of a short circuit or overcurrent, e.g. due to a collision or submersion in water, the battery control unit will interrupt the high voltage. The high voltage can also be interrupted by a blown fuse.
- The disconnection of the high voltage circuit is linked to the power switch.
- The high voltage circuit is interrupted when the power switch is switched OFF.

About lithium-ion batteries

- The ZR-V e:HEV is powered by a high-voltage lithium-ion battery (drive battery) in addition to the 12 V automotive battery.
- The lithium-ion battery has a total voltage of more than 260 V
- The electrolyte is also sealed in the battery and does not need to be replaced or replenished.
- If the lithium-ion battery is damaged, there is no risk of leaking a large amount of electrolyte. For information on what to do in the event of a leak, see the next section.

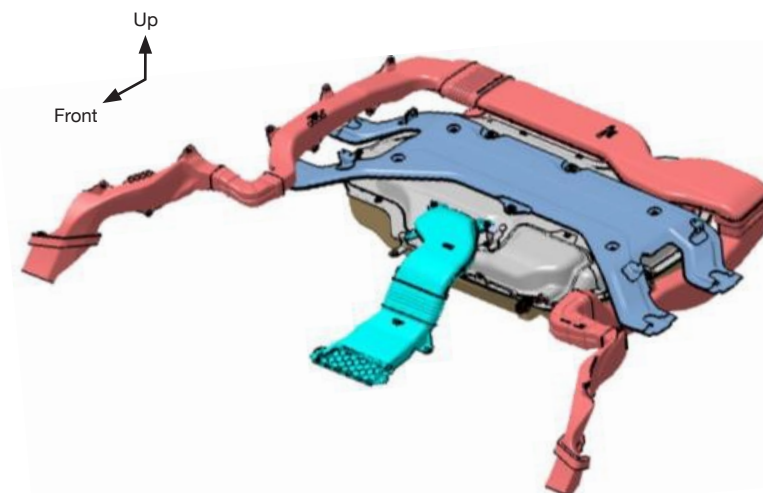

The battery assembly cover should never be breached or removed under any circumstances, including fire. Doing so might result in severe electrical burns, shocks, or electrocution.



Never touch the components inside the high-voltage components or the conductors of the high-voltage wiring if they are exposed due to vehicle damage. Unintentional touching of high-voltage components may result in serious injury or death due to severe burns or electric shock.

If you have no choice but to touch or may touch the exposed parts of the high-voltage cable or high-voltage components, always wear insulating protective equipment [insulated gloves, safety glasses and insulated shoes].

What to do in the event of a lithium-ion battery leak

- The electrolyte in the ZR-V e:HEV lithium-ion battery contains volatile organic solvents. It is also colourless and transparent and cannot be identified by sight.
- If leaks are observed near the lithium-ion battery and electrolyte is suspected, wear solvent-resistant protective equipment [gas mask (for organic gases)].
- Always wear a gas mask (for organic gases) and rubber gloves (for chemical resistance)] and wipe up the leaked liquid with a dry rag. Store used rags, etc. in sealable bags or containers and dispose of them properly as industrial waste.



The electrolyte in lithium-ion batteries is harmful to the human body and may cause blindness or injury if it gets into the eyes or gets on the skin. In the event of contact with electrolyte in the eyes or on the skin, immediately flush with plenty of water and seek professional medical advice.

Lithium-Ion Battery Fumes or Fire

A damaged high-voltage lithium-ion battery can emit toxic fumes, and the organic solvent used as electrolyte is flammable and corrosive. Responders should wear appropriate personal protective equipment. Even after a lithium-ion battery fire appears to have been extinguished, a renewed or delayed fire can occur. The battery manufacturer cautions responders that extinguishing a lithium-ion battery fire will take a large and sustained volume of water.



In order to minimize the possibility of collateral fire damage, responders should always ensure that a Honda ZR-V e:HEV with a damaged battery is kept outdoors and far away from other flammable objects.

















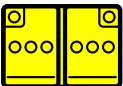



Lithium-Ion Battery Fluid

Avoid contact with the high-voltage battery fluid. The high-voltage battery contains a flammable electrolyte that could leak as a result of a severe crash. Avoid any skin or eye contact with the electrolyte as it is corrosive. If you accidentally touch it, flush your eyes or skin with a large quantity of water for at least 5 minutes and seek medical attention immediately.

Disposal

The lithium-ion battery, the high-voltage battery fluid, and the water used to discharge the battery must be properly disposed of as industrial waste according to local regulations.

Fluids and gases used in this vehicle

Type	Capacity	Dangers
 Li-ion	262.8 V	     
	12 V	 
	R-1234yf 435-485 g	   
	57 L	 
Engine Oil	4,0 L	
Engine Coolant	7,4 L	
Transaxle Fluid	2,2 L	



HV-battery is air-cooled, no water cooling fluid!



6. In case of fire

Fire precautions and procedures

In the event of a vehicle fire, extinguish the fire by spraying large quantities of water to cool the battery. If it is difficult to discharge large quantities of water, use an ABC fire extinguisher (for both oil and electrical fires). In case of fire, use an ABC fire extinguisher (for both oil and electrical fires). In the event of fire, the insulating coating of the electrical wiring burns, causing a short circuit, which in turn blows the fuse in the power system and interrupts the high voltage. A short circuit can also be caused by leakage of electricity due to a large amount of water spraying, which may blow the fuses of the power system and interrupt the high voltage.

The fuses of the power system and the main fuse of the lithium-ion battery can blow, thereby interrupting the high voltage.

Depending on the location of the fire, high voltage may not be interrupted in some circumstances, e.g. if the fuse does not blow or if there is no leakage of electricity due to water spray. After extinguishing the fire, disconnect the high voltage according to 'Methods of shutting down high voltage systems' on page 10.

Note: None of the components used in the high-voltage system of the ZR-V e:HEV are explosive.



USE LARGE AMOUNTS OF PURE WATER



**POTENTIAL RISK OF HV-BATTERY FIRE RE-IGNITION /
DELAYED FIRE!**



Cooling opening

In case of a fire within the high-voltage battery, water can be applied into the battery through the cooling opening.



Responders should always protect themselves with Personal Protective Equipment (PPE), including a Self-Contained Breathing Apparatus (SCBA), and take appropriate measures to protect civilians downwind from the incident.

7. In case of submersion

Submerged Vehicle

If a Honda ZR-V e:HEV is submerged or partly submerged in water, first pull the vehicle out of the water, then shut down the high-voltage system.

See Section 3 (Disable Direct Hazards / Safety Regulations for the high-voltage shutdown procedures).

If touching high-voltage cables and other high-voltage components is unavoidable, personal protective equipment (insulating gloves, goggles, and boots) should always be worn.

Aside from severe damage to the vehicle, there is no risk of an electric shock from touching the vehicle's body or framework—in or out of the water. If the high-voltage battery was submerged, you may hear noises from the battery as the cells are being discharged from shorting.

See Section 8 (Towing/Transportation/Storage) for additional procedures including discharging the high voltage battery.



- If water enters the driving battery, hydrogen gas may be generated.
- When seawater enters, a large amount of hydrogen gas is generated by rapid electrolysis due to salinity, which may cause a fire.
- If you lift the vehicle, please open the windows and doors as there may be hydrogen gas in the car.

Precautions and procedures when submerged in water

When the vehicle is submerged, a short circuit due to leakage caused by water ingress will cause the power system fuses and the main fuse of the lithium-ion battery to blow, thereby interrupting the high voltage.

In some circumstances, such as shallow water depths or submergence in areas where leakage does not occur due to water ingress, the high voltage may not be interrupted, so if possible, disconnect the high voltage according to 'Methods of shutting down high voltage systems' on page 10.



8. Towing / transportation / storage

Accidental vehicle transport guidelines



- If the orange high-voltage cable or high-voltage cover is damaged and exposed wiring or terminals are found, never touch these exposed parts. Also, if you are unsure whether the exposed wires or terminals are high voltage parts or not, do not touch them. Unintentional touching may result in serious injury or death due to severe burns or electric shock.
- Always wear insulating protective equipment [insulated gloves, safety glasses and insulated shoes] when unavoidably touching or potentially touching exposed parts of high-voltage cables or high-voltage components.

Vehicle data

Car model \ Data	Overall length (mm)	Overall width (mm)	Overall height (mm)	Wheel base (mm)	Vehicle weight (kg)
ZR-V e:HEV	4568	1840	1610-1620	2657	1660~1710*

* Depends on the grade





Towing guidelines

Towing should be carried out in accordance with the following guidelines.

- Shall lift all four wheels or the front wheels.
- Tow ropes etc. must only be hung from the front/rear towing hooks (front/rear tie-down slots must only be used when securing the vehicle).
- Do not use bumpers to lift vehicles.
- Do not tow the vehicle in a way that causes damage to the vehicle.
- The speed must be less than 30 km/h and the towing distance must not exceed 80 km (except for towing by lifting four wheels).
- If the front and rear wheels are stuck, the four wheels shall be lifted and transported.
- If the N position is not reached, the four wheels shall be lifted and transported.
- Towing according to road traffic laws.

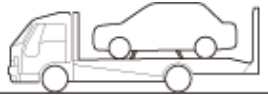
Note: On this model, it is possible to change the vehicle settings so that the parking brake is automatically activated when the power mode is set to OFF mode. If necessary, turn off the automatic parking brake activation function to prevent the parking brake from being applied when towing.

Towing should be carried out in accordance with the table below.

Towing method	Towability	Shift position	Conditions or notes
<p>Flat bed</p> 	2WD	P-position	Always secure the vehicle to prevent it from ejecting. The vehicle must be secured so that it does not fly out of the vehicle. Apply parking brake.
<p>Towing by lifting the front wheels</p>  <p>Towing by trekker</p> 	2WD	N-position	<p>How to switch to position holding mode.(1) With the brake depressed, press the power switch to READY state. (2) Set the shift position to N position. (3) With the brake pedal depressed, press the “N” button again and simultaneously press the power switch. (4) Press the power switch at the same time as pressing the “N” button again while keeping the brake pedal depressed. Check that the multi-information display shows “Please put the car in parking”. (5) After the state shown in (4), disconnect the minus (-) terminal of the 12 V battery. Disconnect the minus (-) terminal of the 12 V battery.</p>
<p>Towing by rope</p> 	X	-	If the vehicle is towed with the front wheels on the ground, the motor may spin and damage the system.

Tow hook/tie-down Slot position

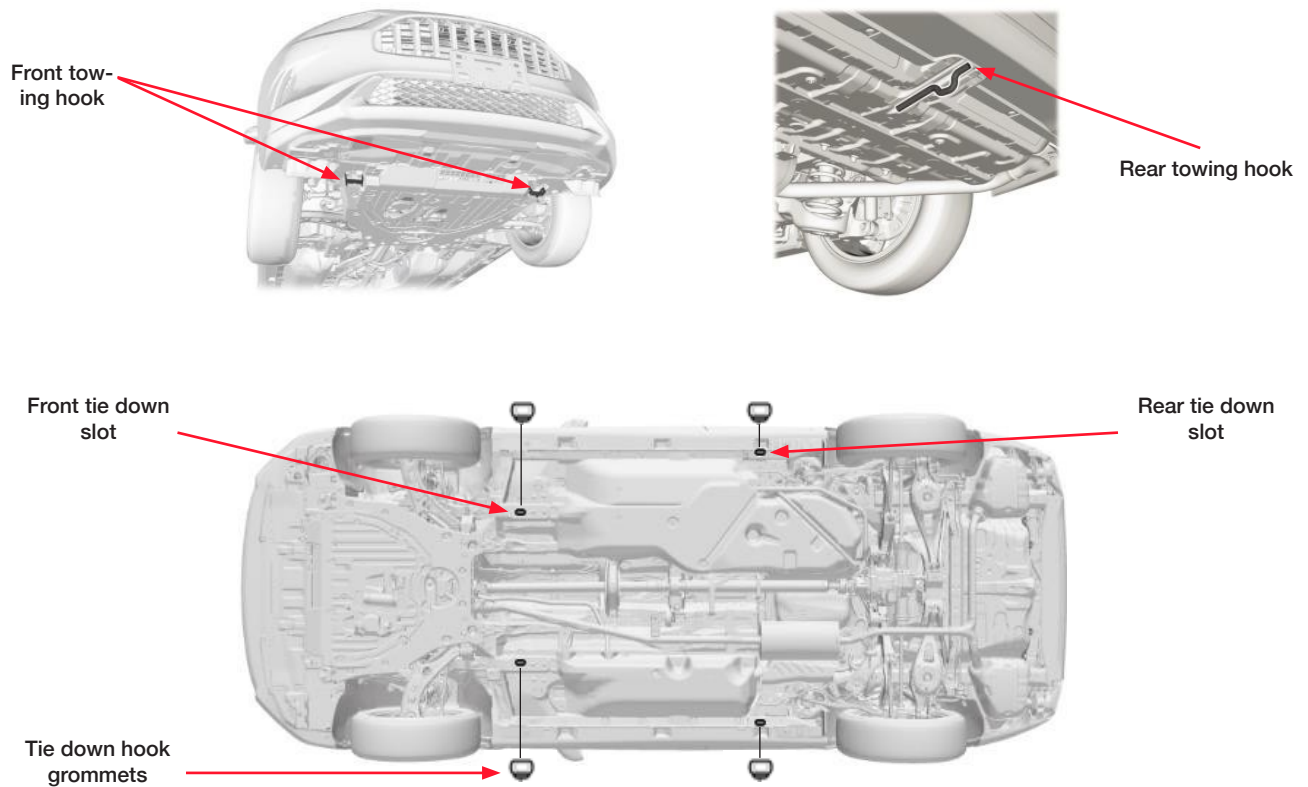

**STORE VEHICLE IN AN OPEN-AIR PARKING AT A SAFE DISTANCE
≥ 5M FROM OTHER AROUND OBJECTS OR VEHICLES!**

**POTENTIAL RISK OF HV-BATTERY FIRE RE-IGNITION /
DELAYED FIRE!**



9. Important additional information

Seat Belts and Airbags

The Honda ZR-V e:HEV is equipped with lap/shoulder belts in all seating positions. The front seat belts are equipped with pyrotechnically activated tensioners that help tighten the seat belt in a sufficient crash.

In addition, the Honda ZR-V e:HEV is equipped with the following airbags:

- Front Airbags – Driver/Front Passenger
- Front center airbag – Driver/Front Passenger
- Side Airbags – Driver/Front Passenger
- Side Curtain Airbags – Driver's Side/Passenger Side

It takes up to 3 minutes for the airbags and tensioners to power off after the 12-volt system has been turned off by following the emergency shutdown procedures described in this guide.

In a collision severe enough to deploy one or more of the airbags, the Honda ZR-V e:HEV electrical system is designed to automatically open the high-voltage electrical contactors. This disconnects the high-voltage battery from the other high-voltage components and stops the flow of electricity in the high-voltage cables.

However, responders should always assume that the high-voltage system is powered on, and take the appropriate action described in this guide to power off the system.

Position of airbag-related components

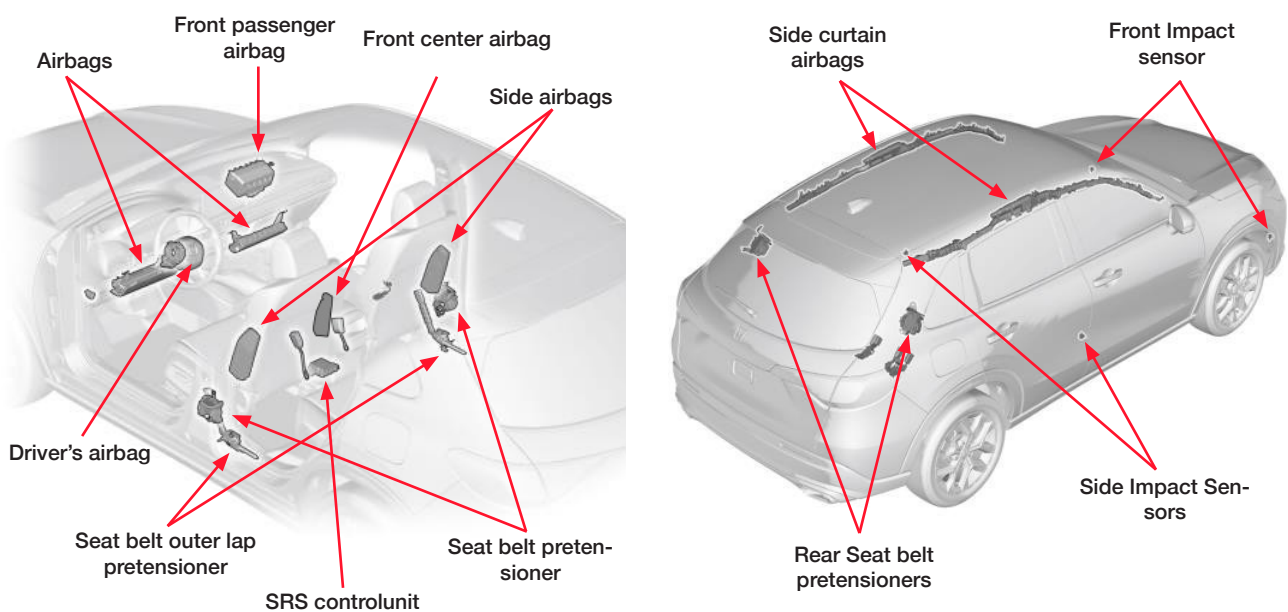

Vehicle Collision

In the event of a crash, the supplemental restraint system (SRS) unit makes a judgment based on input from the impact sensors. If the input values meet various threshold requirements, the SRS unit sends a signal to the high-voltage battery electronic control unit (ECU). The high-voltage battery ECU then turns off the high-voltage battery contactors, stopping the flow of electrical current from the high-voltage battery.

When responding to an incident involving a Honda ZR-V e:HEV, we recommend that emergency personnel follow their organization's standard operating procedures for assessing and dealing with vehicle emergencies.

Honda recommends that responders follow the procedures in this guide to avoid potentially lethal shock from high voltage.

Lithium-ion battery damage precautions and procedures

- If the lithium-ion battery has been damaged, e.g. in a collision, observe the following warnings.
- In the unlikely event of a suspected leak, follow the section 'What to do in the event of a lithium-ion battery leak' on page 19.



- If the orange high-voltage cable or high-voltage cover is damaged and exposed wiring or terminals are found, never touch these exposed parts. Also, if you are unsure whether the exposed wires or terminals are high voltage parts or not, do not touch them. Unintentional touching may result in serious injury or death due to severe burns or electric shock.
- If you have no choice but to touch or may touch the exposed parts of the high-voltage cables or high-voltage components, always wear insulating protective equipment [insulated gloves, protective glasses and insulated shoes].

Electric Shock

















Unprotected contact with any electrically charged high-voltage component can cause serious injury or death. Receiving an electric shock from a Honda ZR-V e:HEV, however, is highly unlikely because of the following:

- Contact with the battery module or other high-voltage components can only occur if they are damaged and the contents are exposed, or if they are accessed without following proper precautions.
- Contact with the electric motor can only occur after one or more components are removed.
- The high-voltage cables can be easily identified by their distinctive orange color, and contact with them can be avoided.



If severe damage causes high-voltage components to become exposed, responders should take appropriate precautions and wear appropriate insulated personal protective equipment.

10. Explanation of pictograms used

	Warning high voltage		Hybrid Electric Vehicle on fuel of liquid group 2
	Caution		Flammable
	Warning; low temperature		Hazardous to the human health
	Air-conditioning component		Acute toxicity
	Use water to extinguish the fire		Explosive
	Use thermal infrared camera		Corrosives
	Battery pack, high-voltage		Fuel tank content gasoline/ethanol
	Battery low voltage		Special battery access



HONDA